

# Configuración de arrancadores Estrella-Triángulo



Potencia motor (kW en AC3)				Intensidad	Referencia de arrancador λ-Δ	Línea KM2	Δ KM3	λ KM1	auxiliar KM1	Temporizador neumático	Térmico (*)
220V	380V	415V	440V								
4	7.5	7.5	7.5	9	SGC3-D093P7	SGC1-D0910W-P7	SGC1-D0901W-P7	SGC1-D0901W-P7	SGA1-DN11	SGA2-DT2	SGR2-D1314
5.5	11	11	11	12	SGC3-D123P7	SGC1-D1210W-P7	SGC1-D1201W-P7	SGC1-D0901W-P7	SGA1-DN11	SGA2-DT2	SGR2-D1316
7.5	15	15	18.5	18	SGC3-D183P7	SGC1-D1810W-P7	SGC1-D1801W-P7	SGC1-D1201W-P7	SGA1-DN11	SGA2-DT2	SGR2-D1321
11	18.5	18.5	22	25	SGC3-D253P7	SGC1-D2510W-P7	SGC1-D2501W-P7	SGC1-D1801W-P7	SGA1-DN11	SGA2-DT2	SGR2-D1322
15	25	25	30	32	SGC3-D323P7	SGC1-D3210W-P7	SGC1-D3201W-P7	SGC1-D2501W-P7	SGA1-DN11	SGA2-DT2	SGR2-D2353
18.5	33	33	37	40	SGC3-D403P7	SGC1-D40W-P7	SGC1-D40W-P7	SGC1-D3201W-P7	SGA1-DN11	SGA2-DT2	SGR2-D3355
25	45	45	59	50	SGC3-D503P7	SGC1-D50W-P7	SGC1-D50W-P7	SGC1-D40W-P7		SGA2-DT2	SGR2-D3357
30	55	55	59	65	SGC3-D653P7	SGC1-D65W-P7	SGC1-D65W-P7	SGC1-D50W-P7		SGA2-DT2	SGR2-D3359
37	63	63	75	80	SGC3-D803P7	SGC1-D80W-P7	SGC1-D80W-P7	SGC1-D65W-P7		SGA2-DT2	SGR2-D3361
45	80	80	80	95	SGC3-D953P7	SGC1-D95W-P7	SGC1-D95W-P7	SGC1-D80W-P7		SGA2-DT2	SGR2-D3365

Temporizador opcional electrónico
DTMUCD2
DTMUCD2
DTMUCD2
DTMUCD2
DTMUCD2
DTMUCD2
DTMUCD2
DTMUCD2
DTMUCD2
DTMUCD2
DTMUCD2

Secciones de cableado recomendado (mm²)		
KM2-KM3	KM1-KM3	KM1
2,5	1,5	1,5
2,5	1,5	1,5
4	2,5	2,5
4	2,5	2,5
6	4	4
10	6	6
10	6	6
16	10	10
25	10	10
25	10	10

(\*) Ajustar el térmico a 0,58 x Intensidad de empleo del motor

Esquema de potencia

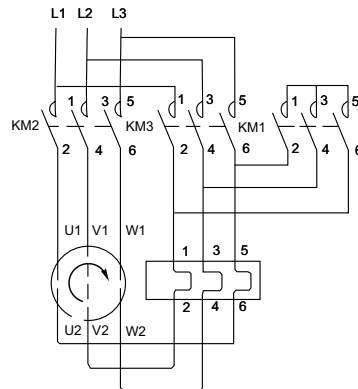

Esquema de control

